



NME454 – 400 lb Nugget Ice Machine

Modular Nugget Ice Machine with AutoSentry™



Shown on BH550S-C bin.

Key Advantages

AutoSentry™ Monitoring System constantly checks workload on gearbox shutting down system before a problem develops preventing costly repairs.

Electrical conductivity **water sensor** eliminates low or no water failures and cannot be affected by adverse water conditions.

Plastic drain pan with larger outlet provides greater ability to quickly channel water away **preventing particulate build-up and rust.**

Rust and restriction free drain system features one-piece plastic drain tubes with larger ID for **obstruction-free water flow.**

Durable, high grade stainless steel construction with massive, self-aligning spherical roller bearings; patented double-flight auger that evenly distributes the load; and heavy duty direct drive gearbox for **high reliability and long life.**

24 Hour Volume Production

Air Cooled		
70°F/21°C 50°F/10°C lb/kg	Air Water	90°F/32°C 70°F/21°C lb/kg
460/209		370/168

Water Cooled		
70°F/21°C 50°F/10°C lb/kg	Air Water	90°F/32°C 70°F/21°C lb/kg
510/232		420/191



Modular Bin Options

Model Number	Dimensions W" x D" x H"	ARI Certified Bin Capacity lb/kg	Application Capacity lb/kg	Finish	Ship Weight lb/kg
HTB250-H*	30 x 31.5 x 22.5	190/86	250/113	Poly	80/36
HTB350-H*	30 x 31.5 x 29.5	250/113	350/159	Poly	90/41
HTB555-H*	30 x 34.5 x 44.5	420/190	535/243	Poly	110/50
BH550S-C*	30 x 31.5 x 44	410/186	520/236	SS	140/64
BH801S-A*	42 x 31.5 x 44	580/263	740/336	SS	165/75
BH900S-C*	48.2 x 33.75 x 44	740/336	940/426	SS	200/91

*See price list for Bin Top.



Bin: HTB350-H



Bin: HTB555-H

Nugget Ice



The Original Chewable Ice™!
Cools drinks rapidly without foaming.
Used in fountain beverages.

Warranty

- 3 years parts and labor on all components.
- 5 years parts on the compressor.

Warranty valid in North, South & Central America.
Contact factory for warranty in other regions.

Scotsman™

The Smart Choice in Ice.™

NME454 – 400 lb Nugget Ice Machine

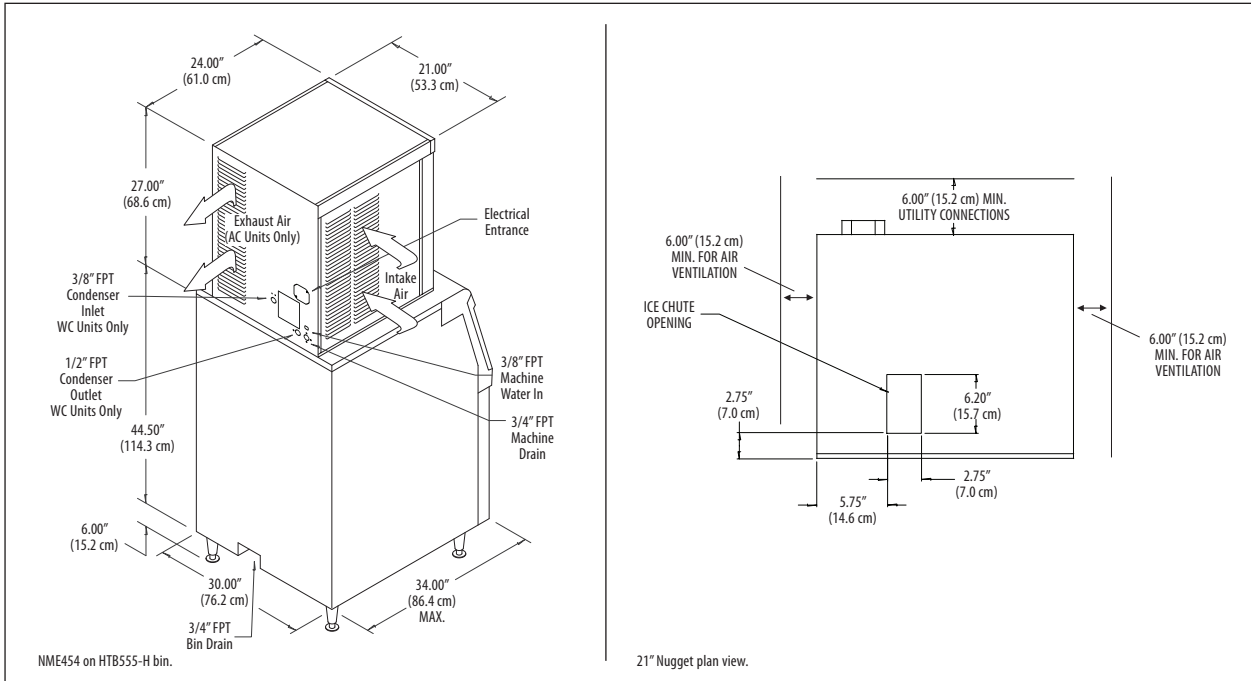

Specifications

Model Number	Condenser Unit	Basic Electrical Volts/Hz/Phase	Max. Fuse Size or HACR Circuit Breaker (amps)	Circuit Wires	Min. Circuit Ampacity	Energy Consumption kWh/100 lb (45.4 kg) 90°F(32°C)/70°F(21°C)	Water Usage Gallons/100 lb (liters/45.4 kg)	
							Potable 90°F(32°C)/70°F(21°C)	Condenser 90°F(32°C)/70°F(21°C)
NME454AS-1A	Air	115/60/1	20	2	15.75	5.2	12.0/45.5	-
NME454WS-1B	Water	115/60/1	20	2	14.35	4.2	12.0/45.5	71.2/269.8

All Models

Dimensions (W x D x H):
Unit:
21" x 24" x 27"
(53.3 x 61.0 x 68.6 cm)

Shipping Carton:
28" x 25" x 32"
(71.1 x 63.5 x 81.3 cm)

Shipping Weight:
205 lb/93 kg

BTUs per hour:
5,600

Accessories

Model Number	Description

* Scotsman recommends all ice machines have water filtration. See Scotsman Sanitation Matrix for details.

Operating Requirements

	Minimum	Maximum
Air Temperatures	50°F (10°C)	100°F (38°C)
Water Temperatures	40°F (4.4°C)	100°F (38°C)
Remote Cond. Temps	-20°F (-29°C)	120°F (49°C)
Water Pressures	20 PSIG (1.4 bar)	120 PSIG (8.3 bar)
Electrical Voltage	-5%	+10%

Specifications and design are subject to change without notice.

Scotsman Ice Systems
775 Corporate Woods Parkway
Vernon Hills, IL 60061

1-800-SCOTSMAN
Fax: 847-913-9844
E-mail: customer.service@scotsman-ice.com

www.scotsman-ice.com